

Mounting Bracket for UHF Conveyor Antenna

A-UHF-MMB-6



Product Description

A-UHF-MMB-6 is a metallic, robust and versatile mounting bracket used in combination with the UHF Conveyor Antenna (A-UHF-CON-101; A-UHF-CON-115; A-UHF-CON-131) for almost every application. The round plate has several combinations of holes that allow it to be fixed in different ways.

Technical drawings

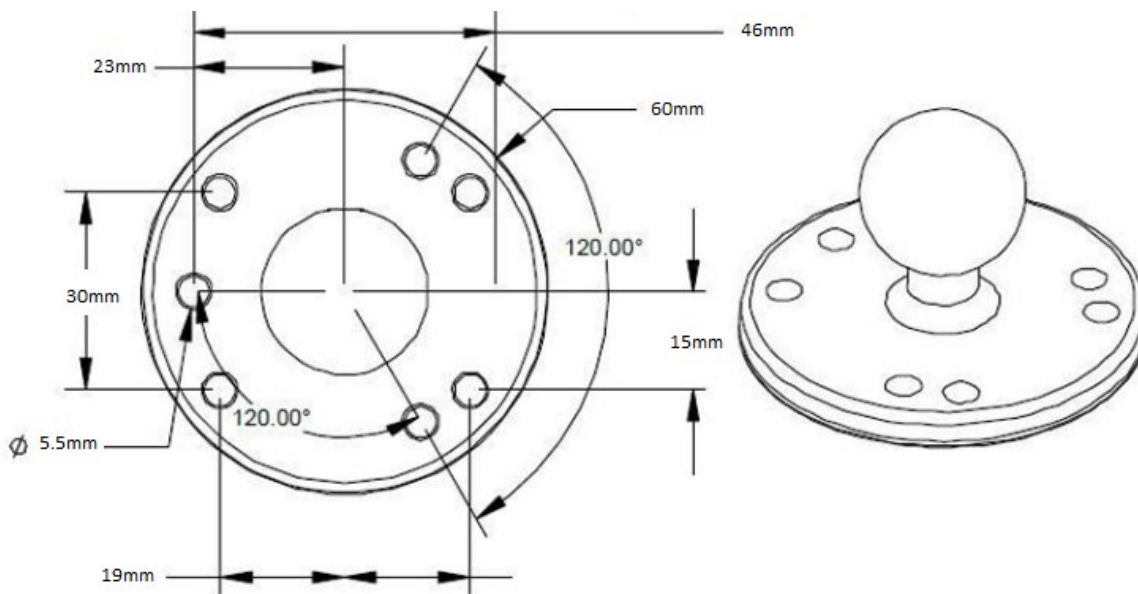

Mounting Bracket for UHF Conveyor Antenna

A-UHF-MMB-6

Technical data

Length:	190mm
Weight:	500g
Material: Metal	Metal

Ordering information

A-UHF-MMB-6	400 3075-250
-------------	--------------